

透明印刷釉 Transparent Printing Glaze

編號 No.	體膨脹係數 Coefficient of thermal expansion ($\times 10^{-6}/^{\circ}\text{C}$)	燒成條件 Firing Range	使用說明 Descriptions
CS-9602R	180	1100-1180°C	中溫透明印刷釉，適用於滾筒印刷使用。 Medial temperature transparent printing glaze for rotor printing.
★ CS-9603	387	1000-1100°C	一、二次燒地、壁磚使用，有深陷效果。 Suitable for single or double fast firing with seeking effect.
★ CS-9608	195	1000-1100°C	一、二次燒地、壁磚使用，有深陷效果 Suitable for single or double fast firing with seeking effect.
CS-9617R	198	1000-1080°C	低溫透明印刷釉，當印刷釉粉百分比少，色料百分比多時，使用此印刷釉，可得到平且亮的釉面。 Low temperature transparent printing glaze, suitable for lower percentage of printing glazes and higher percentage of pigments with a smooth and glossy surface.
CS-9624	205	1160-1200°C	一次燒地磚透明印刷釉。 Transparent printing glaze for single fast firing floor tiles.
CS-9627R	208	1160-1200°C	高溫透明無光印刷釉，適用於滾筒印刷使用。 High temperature transparent matt printing glaze for rotor printing.
CS-9628A	210	1160-1200°C	一次燒地磚透明無光印刷釉。 Transparent matt printing glaze for single fast firing floor tiles.
CS-9628R	210	1170-1210°C	高溫透明無光印刷釉，適用於滾筒印刷使用。 High temperature transparent matt printing glaze for rotor printing.
CS-9630R	200	1180-1220°C	高溫透明無光印刷釉，適用於滾筒印刷使用。 High temperature transparent matt printing glaze for rotor printing.
CS-9647R	200	1100-1180°C	中溫透明印刷釉，適用於滾筒印刷使用。 Medial temperature transparent printing glaze for rotor printing.
CS-9647CR	200	1100-1180°C	中溫透明印刷釉，適用於滾筒印刷使用。 Medial temperature transparent printing glaze for rotor printing.
CS-9648R	198	1100-1180°C	中溫透明印刷釉，適用於滾筒印刷使用。 Medial temperature transparent printing glaze for rotor printing
CS-9656	387	1100-1200°C	一次燒地、壁磚使用，有深陷效果。 Suitable for single fast firing floor or wall tiles with seeking effect.

★ 屬訂真生產之產品，訂貨之交貨期限 1 個月

★ Produced by order, one month for production delivery.

1. 上列印刷釉係 325 mesh 之粉末，每包 25 kgs 包裝。

The above screen printing glazes are 325 mesh powder and packed with 25kgs paper bag.

2. 上列印刷釉編號有“R”字，係表示粒度精細之粉末，其粒度為 $d(0,9) \leq 13\mu\text{m}$ (400 mesh=37 μm)。

The above code of printing glazes with “R”, indicating they are fine powder. Particle size is $d(0,9) \leq 13\mu\text{m}$ (400 mesh=37 μm).

乳白印刷釉 Opaque Printing Glaze

編號 No.	體膨脹係數 Coefficient of thermal expansion ($\times 10^{-7}/^{\circ}\text{C}$)	燒成條件 Firing Range	使用說明 Descriptions
CS-9308	186	1160-1200°C	一次燒地磚浮凸耐磨印刷釉。 Opaque and matt glaze with relief and attrition resistant effect.
★ CS-9311	190	1050-1150°C	一、二次燒閃光印刷釉。 Luster printing glaze for single or double fast firing.
★ CS-9313	205	1120-1170°C	一次燒閃光印刷釉。 Luster printing glaze for single fast firing.
CS-9804	212	1160-1200°C	一次燒地磚乳白印刷釉。 Opaque printing glaze for single fast firing floor tiles.
CS-9808	175	1160-1200°C	無光浮凸印刷釉，適用於一次燒高亮地、壁磚。 Opaque and matt glaze with relief effect in high glossy floor or wall tiles.
CS-9813R	185	1100-1180°C	中溫乳白印刷釉，適用於滾筒印刷使用。 Medial temperature opaque printing glaze for rotor printing.
CS-9816R	180	1100-1160°C	含氧化錫之白度特佳滾筒印刷釉，有暨白且平釉面的效果。 Printing glaze with SnO ₂ content, having excellent whiteness and smooth surface.
CS-9821R	165	1000-1080°C	低溫乳白印刷釉，當印刷釉粉百分比少，色料百分比多時，使用此印刷釉，可得到平且亮的釉面。 Low temperature opaque printing glaze, suitable for lower percentage of printing glazes and higher percentage of pigments with a smooth and glossy surface
CS-9822	197	1140-1200°C	一次燒地、壁磚乳白印刷釉。 Opaque printing glaze for single fast firing floor or wall tiles.
★ CS-9823	174	1160-1200°C	白度特佳之一次燒印刷釉。 Good whiteness screen printing glaze for single fast firing.

- ★ 屬訂貨生產之產品，訂貨之交貨期限 1 個月
★ Produced by order, one month for production delivery.

1. 上列印刷釉係 325 mesh 之粉末，每包 25 kgs 包裝。
The above screen printing glazes are 325 mesh powder and packed with 25kgs paper bag.
2. 上列印刷釉編號有“R”字，係表示粒度精細之粉末，其粒度為 $d(0,9) \leq 13\mu\text{m}$ (400 mesh=37 μm)。
The above code of printing glazes with “R”, indicating they are fine powder. Particle size is $d(0,9) \leq 13\mu\text{m}$ (400 mesh=37 μm).

乾粒釉 Vetrosa Glazes

編號 No.	體膨脹係數 Coefficient of thermal expansion ($\times 10^{-7}/^{\circ}\text{C}$)	軟化點 (攝氏°C) Dilatometer softening point($^{\circ}\text{C}$)	使用說明 Descriptions
CD-7637 系列 (XD-4037 系列)	200	770	一次燒高溫無光乾粒，可做半拋得到透明效果，適合於 1190~1230°C 燒成。 Suitable for single firing matt vetrosa, can choose semi-polishing to get transparent effect, used for 1190~1230°C.
★ CD-7662 系列 (XD-4062 系列)	205	745	一次燒高溫無光乾粒，可做半拋得到透明效果，適合於 1170~1200°C 燒成。 Suitable for single firing matt vetrosa, can choose semi-polishing to get transparent effect, used for 1170~1200°C.
CD-7671 系列	245	725	一次燒高溫透明乾粒，可做砂糖效果，適合於 1180~1220°C 燒成。 Suitable for single firing transparent vetrosa, suitable for suger effect, used for 1180~1220°C.
CD-75178 系列	200	770	一次燒地磚使用之亞光乾粒釉，適合於 1180~1220°C 燒成。 Matt effect vetrosa, Suitable for single firing floor tiles, firing temperature range is 1180~1220°C
★ CD-75180 系列	215	775	一次燒地磚使用之亞光乾粒釉，適合於 1180~1220°C 燒成。 Matt effect vetrosa, Suitable for single firing floor tiles, firing temperature range is 1180~1220°C

★ 屬訂貨生產之產品，訂貨之交貨期限 1 個月

★ Produced by order, one month for production delivery.

產品粒度規格：

SL: 60~120 目

SM(S): 120~200 目

SS: 200~325 目

M: 80~150 目

Partical size:

SL: 60~120 mesh

SM(S): 120~200 mesh

SS: 200~325 mesh

M: 80~150mesh

陶瓷釉用色料 Glaze Stains(1/2)

編號 No.	色名	Color	成份 Components	最高燒成溫度 Maxfiring Temp.	備註 Remarks
★ CP-100	硃紅色	Red	Zr-Si-Se-Cd	1200°C	適用各種釉藥 Suitable for all glaze.
CP-201 (CP-201A)	水青色	Turquoise Blue	Zr-V-Si	1300°C	適合各種釉藥尤適用於含鋯釉藥 Suitable in all glazes especially in zircon opaque glazes.
CP-232	深藍色	Dark Blue	Co-Si-Al	1300°C	適用各種釉藥 Suitable for all glaze.
CP-236	深藍色	Dark Blue	Co-Al	1300°C	適用各種釉藥 Suitable for all glaze.
CP-256	孔雀藍	Peacock Blue	Co-Cr	1300°C	適用含鋅釉藥 Suitable in glazes with ZnO content.
CP-302	綠色	Green	Cr-Al	1300°C	適用含鋅釉藥 Suitable in glazes with ZnO content.
CP-306	綠色	Green	Cr-Al	1300°C	適用含鋅釉藥 Suitable in glazes with ZnO content.
CP-321	橄欖色	Olive	Zr-Si-Pr-Fe	1250°C	適用含鋅釉藥 Suitable in glazes with ZnO content.
CP-342	綠色	Green	Zr-Si-V-Pr	1250°C	適用各種釉藥 Suitable for all glaze.
CP-402	黃色	Praseodymium Yellow	Zr-Si-Pr	1250°C	適合各種釉藥尤適用於含鋯釉藥 Suitable in all glazes especially in zircon opaque glazes.
CP-406	黃色	Praseodymium Yellow	Zr-Si-Pr	1200°C	適合各種釉藥尤適用於含鋯釉藥 Suitable in all glazes especially in zircon opaque glazes.
CP-408	黃色	Praseodymium Yellow	Zr-Si-Pr	1200°C	適合各種釉藥尤適用於含鋯釉藥 Suitable in all glazes especially in zircon opaque glazes.
★ CP-445 (XP-545)	黃色 (比其色)	Yellow (Beige)	Zr-Si-Pr-Fe-Zn	1200°C	適用各種釉藥 Suitable for all glaze.
CP-504 (CP-504A)	珊瑚色	Coral Pink	Zr-Fe-Si	1300°C	適合各種釉藥尤適用於含鋯釉藥 Suitable in all glazes especially in zircon opaque glazes.
CP-504 (CP-504A)	珊瑚色	Coral Pink	Zr-Fe-Si	1300°C	適合各種釉藥尤適用於含鋯釉藥 Suitable in all glazes especially in zircon opaque glazes.
CP-515	粉紅	Pink	Sn-Cr-Ca-Si	1300°C	適用在無鋅、高鈣成份釉藥 Use ZnO free glazes with CaO PbO BaO content.
★ CP-551	瑪瑙色	Maroon red	Sn-Cr-Ca-Si	1300°C	適用在無鋅、高鈣成份釉藥 Use ZnO free glazes with CaO PbO BaO content.
CP-554	瑪瑙色	Maroon red	Sn-Cr-Ca-Si	1300°C	適用在無鋅、高鈣成份釉藥 Use ZnO free glazes with CaO PbO BaO content.
CP-559	瑪瑙色	Maroon red	Sn-Cr-Ca-Si	1300°C	適用在無鋅、高鈣成份釉藥 Use ZnO free glazes with CaO PbO BaO content.

★ 屬訂貨生產之產品，訂貨之交貨期限 1 個月

★ Produced by order, one month for production delivery.

陶瓷釉用色料 Glaze Stains(2/2)

編號 No.	色名	Color	成份 Components	最高燒成溫度 Maxfiring Temp.	備註 Remarks
CP-701	深棕色	Dark Brown	Fe-Cr-Zn-Ni	1300°C	適用含鋅釉藥 Suitable in glazes with ZnO content.
CP-714	紅棕色	Red Brown	Fe-Cr-Zn	1300°C	適用含鋅釉藥 Suitable in glazes with ZnO content.
★ CP-732	棕色	Brown	Fe-Cr-Zn	1300°C	適用含鋅釉藥 Suitable in glazes with ZnO content.
CP-742	黃棕色	Yellowish brown	Fe-Cr-Zn-Al	1300°C	適用含鋅釉藥 Suitable in glazes with ZnO content.
CP-746	黃棕色	Yellowish brown	Fe-Cr-Zn-Al	1300°C	適用含鋅釉藥 Suitable in glazes with ZnO content.
CP-749 (XP-7496)	黃棕色	Yellowish brown	Fe-Cr-Zn-Al	1300°C	適用含鋅釉藥 Suitable in glazes with ZnO content.
CP-801A	灰色	Gray	Zr-Co-Ni	1250°C	適用各種釉藥 Suitable for all glaze.
CP-805	灰色	Gray	Zr-Co-Ni-Si	1300°C	適用各種釉藥 Suitable for all glaze.
CP-816	灰色	Gray	Zr-Co-Ni-Si-Pr-Fe	1300°C	適用各種釉藥 Suitable for all glaze.
★ CP-827	灰色	Gray	Zr-Co-Ni-Si-Pr-Fe	1300°C	適用各種釉藥 Suitable for all glaze.
CP-905	黑色	Black	Cr-Co-Fe-Ni	1250°C	適用各種釉藥 Suitable for all glaze.
CP-908	黑色	Black	Cr-Co-Fe-Mn	1250°C	適用各種釉藥 Suitable for all glaze.
CP-910	黑色	Black	Cr-Co-Fe-Mn	1250°C	適用各種釉藥 Suitable for all glaze.
CP-913	黑色	Black	Cr-Ni-Fe-Mn	1250°C	適用各種釉藥 Suitable for all glaze.
CP-915	黑色	Black	Cr-Ni-Fe-Mn	1250°C	適用各種釉藥 Suitable for all glaze.
CP-916	黑色	Black	Cr-Ni-Fe-Mn	1250°C	適用各種釉藥 Suitable for all glaze.
★ CP-966	黑色	Black	Cu-Co-Fe-Mn	1100°C	適用不含熔劑之基材 Suitable for flux free Substrate.

★ 屬訂貨生產之產品，訂貨之交貨期限 1 個月

★ Produced by order, one month for production delivery.

陶瓷坯體用色料 Body Stains

編號 No.	色名	Color	成份 Components	最高燒成溫度 Maxfiring Temp.	備註 Remarks
CP-130B (CP-130)	鐵紅色	Red	Fe	1300°C	適用不含熔劑之坯體 Suitable for flux free bodie.
CP-201B	水青色	Turquoise Blue	Zr-V-Si	1300°C	適用所有坯體 Suitable for all bodies.
CP-237B	藍色	Deep Blue	Co-Al	1300°C	適用所有坯體 Suitable for all bodies.
CP-245B	藍色	Deep Blue	Co-Al	1300°C	適用所有坯體 Suitable for all bodies.
CP-302B	綠色	Green	Cr-Al	1300°C	適用所有坯體 Suitable for all bodies.
CP-306B	綠色	Green	Cr-Al	1300°C	適用所有坯體 Suitable for all bodies.
CP-402B	黃綠	Praseodymium Yellow	Zr-Si-Pr	1200°C	適用所有坯體 Suitable for all bodies.
CP-509B	陶試紅	Pink	Mn-Al	1250°C	適用於鈣、無熔劑之坯體 Use flux free body with CaO content
CP-511B	紅色	Red	Fe-Si-Mn-Al	1250°C	適用不含熔劑之坯體 Suitable for flux free bodie.
CP-521B	陶試紅	Pink	Mn-Al	1250°C	適用於鈣、無熔劑之坯體 Use flux free body with CaO content
★ CP-527B (XP-5272B)	紅色	Red	Fe-Si-Mn-Al	1250°C	適用不含熔劑之坯體 Suitable for flux free bodie.
CP-613B	黃色	Yellow	Ti-Sb-Cr	1200°C	適用不含熔劑之坯體 Suitable for flux free bodie.
★ CP-617B	黃色	Yellow	Ti-Sb-Cr	1200°C	適用不含熔劑之坯體 Suitable for flux free bodie.
CP-625B	黃色	Yellow	Ti-Sb-Cr	1200°C	適用不含熔劑之坯體 Suitable for flux free bodie.
★ CP-631B (XP-6311B)	黃色	Yellow	Ti-Sb-Cr	1200°C	適用不含熔劑之坯體 Suitable for flux free bodie.
CP-805B	灰色	Gray	Cr-Fe-Zr-Si-V	1250°C	適用所有坯體 Suitable for all bodies.
★ CP-826B	灰色	Gray	Cr-Fe-Al-Mn	1250°C	適用所有坯體 Suitable for all bodies.
CP-932B	黑色	Black	Fe-Cr	1200°C	適用所有坯體 Suitable for all bodies.
CP-934B (XP-9341B)	黑色	Black	Fe-Cr	1200°C	適用所有坯體 Suitable for all bodies.
CP-935B	黑色	Black	Fe-Cr	1200°C	適用不含熔劑之坯體 Suitable for flux free bodie.
CP-939B	黑色	Black	Fe-Cr	1200°C	適用不含熔劑之坯體 Suitable for flux free bodie.
CP-942B	黑色	Black	Fe-Cr	1200°C	適用不含熔劑之坯體 Suitable for flux free bodie.

★ 屬訂貨生產之產品，訂貨之交貨期限 1 個月

★ Produced by order, one month for production delivery.

陶瓷乾式製程坯體用色料 Body Stains for Dry Mixed Process

編號 No.	色名	Color	成份 Components	最高燒成溫度 Maxfiring Temp.	備註 Remarks
CP-130BD	鐵紅色	Red	Fe	1300°C	適用不含熔劑之坯體 Suitable for flux free bodie.
CP-201BD	水青色	Turquoise Blue	Zr-V-Sl	1300°C	適用所有坯體 Suitable for all bodies.
CP-245BD	藍色	Deep Blue	Co-Al	1300°C	適用所有坯體 Suitable for all bodies.
CP-306BD	綠色	Green	Cr-Al	1300°C	適用所有坯體 Suitable for all bodies.
CP-405BD	黃綠	Praseodymium Yellow	Zr-Si-Pr	1250°C	適用不含熔劑之坯體 Suitable for flux free bodies.
CP-521BD	陶試紅	Pink	Mn-Al	1250°C	適用於鈣、無熔劑之坯體 Use flux free body with CaO content.
CP-617BD	黃色	Yellow	Ti-Sb-Cr	1200°C	適用不含熔劑之坯體 Suitable for flux free bodie.
CP-626BD	黃色	Yellow	Ti-Sb-Cr	1200°C	適用不含熔劑之坯體 Suitable for flux free bodie.
CP-631BD	黃色	Yellow	Ti-Sb-Cr	1200°C	適用不含熔劑之坯體 Suitable for flux free bodie.
CP-692BD	黃色	Yellow	Ti-Sb-Cr	1200°C	適用不含熔劑之坯體 Suitable for flux free bodie.
CP-723BD	咖啡色	Brown	Ti-Fe-Cr	1200°C	適用不含熔劑之坯體 Suitable for flux free bodie.
CP-754BD	咖啡色	Brown	Ti-Fe-Cr	1200°C	適用不含熔劑之坯體 Suitable for flux free bodie.
CP-934BD	黑色	Black	Fe-Cr	1200°C	適用所有坯體 Suitable for all bodies.
CP-937BD	黑色	Black	Fe-Cr	1200°C	適用不含熔劑之坯體 Suitable for flux free bodie.

使用說明 Description :

乾混坯用色料產品具有高分散性效果，可直接與坯粉進行混合後使用，可減少傳統濕法生產之換料損失，與廢水污染問題，降低生產成本。

Dry mixed body stains can be mixed with body powders directly due to the high disperse character effect. The waste and pollution are reduced in changing material during the process of tradition wet method, thereby the cost of production is decreased.

粉體特性 Characteristics :

細度：325 目 ≤ 1.0%，含水率 ≤ 1.0%

Fineness ≤ 1.0%(325mesh), Moisture content ≤ 1.0%

備註：1. 乾式製程用色料係配合石英磚乾式製程使用之要求

2. 目前乾式製程用色料均屬訂貨生產之產品：訂貨之交貨期限一個月

Remark: 1. Color stain for body stain

2. Produced by order : One month for production delivery.

矽酸鋯 Zirconium Silicate

規格 Specification of ZIROPAX

化學組成 Chemical composition

ZrO ₂	SiO ₂	Fe ₂ O ₃	TiO ₂	Al ₂ O ₃	L.O.I	Moisture
50.00%	45.00%	0.20%	1.00%	5.00%	1.00%	1.00%
min	max.	max.	max.	max.	max.	max.

粒度 Particle size

產品分類	ZR-1	ZR-2	ZR-3	ZR-5A	ZR-8A	ZR-9A	ZR-5D
粒徑 (D50)	≤ 1.0μm	≤ 1.0μm	≤ 1.0μm	≤ 1.2μm	≤ 1.0μm	≤ 1.0μm	≤ 1.2μm
粒徑 (D90)	≤ 2.0μm	≤ 2.0μm	≤ 2.0μm	≤ 6.0μm	≤ 4.0μm	≤ 4.0μm	≤ 6.0μm

HORBIA LA-960 [ZrSiO₄(1.92-0.000i), water(1.330)]

物理性質 Properties of ZIROPAX

比重	Specific Gravity	4.69
熔點	Melting Point	2500°C
折光率	Refractive Index	1.925
硬度	Hardness	7.5
熱膨脹係數	Coefficient of Thermal Expansion	$134.4 \times 10^{-7} \sim 160 \times 10^{-7}$

用途 Usage of ZIROPAX

1. 乳白劑：面磚、地磚、衛瓷、食器、電瓷等釉藥及化妝釉之乳白失透劑（建議使用 ZR-1、ZR-2、ZR-3、ZR-5A、ZR-8A、或 ZR-9A）
Opacifier for glazes：Wall tiles, floor tiles, sanitary ware, cooking ware, electrical porcelain, engobe.....etc. (ZR-1, ZR-2, ZR-3, ZR-5A, ZR-8A, or ZR-9A)
2. 坯體添加：增加白度（建議使用 ZR-5A, ZR-8A, ZR-9A 或 ZR-5D）
Admixture for ceramic body: Whiteness improvement. ZR-5A, ZR-8A, ZR-9A, or ZR-5D)
3. 熔塊原料 Frits
4. 耐火材料 Refractoriness
5. 樹脂、油漆之填充料 Resin and paint filler

包裝 Package

25 公斤紙袋 (25kg paper bag)

陶瓷墨水 Ceramic-Jet Inks

編號	顏色 / 效果	Color /Effect	比重 Density	工作黏度 (cp) Working Viscosity	備註 Remark
CI-P2023	藍色	Blue	1.1~1.3	16.0~11.0	適合地磚 Suitable for floor tile
CI-P2211	藍色	Blue	1.1~1.3	16.0~11.0	適合牆磚 Suitable for wall tile
★ CI-P3011	綠色	Green	1.2~1.4	17.0~11.0	
★ CI-P3431	綠色	Green	1.2~1.4	17.0~11.0	
CI-P4021	黃色	Yellow	1.2~1.4	21.0~11.0	
★ CI-P4411	黃色	Yellow	1.2~1.4	17.0~11.0	
CI-P4615	黃色	Yellow	1.2~1.5	17.0~11.0	
CI-P5022	粉紅色	Pink	1.2~1.4	17.0~11.0	
CI-P5022S	粉紅色	Pink	1.2~1.5	17.0~11.0	
★ CI-P5511	紅橙色	Orange Red	1.2~1.4	17.0~11.0	
CI-P6012	比其色	Beige	1.2~1.4	17.0~11.0	
CI-P7023	棕色	Brown	1.2~1.4	16.0~11.0	
CI-P7031	深棕色	Dark Brown	1.2~1.4	16.0~11.0	
CI-P7031S	深棕色	Dark Brown	1.2~1.5	16.0~11.0	
CI-P9021	黑色	Black	1.2~1.4	17.0~11.0	
CI-P9221	棕黑色	Brownish Black	1.2~1.4	17.0~11.0	
CI-R2102	下陷 窯變效果	Reactive Effect	1.1~1.3	18.0~11.0	
★ CI-N1012	負離子	Negative Ion	1.0~1.2	19.0~11.0	
★ CI-L3011	閃光效果	Luster Effect	1.1~1.3	19.0~11.0	適合牆磚 Suitable for wall tile
CI-G1011	透明亮效果	Glossy Transparent	1.1~1.3	16.0~11.0	
CI-G2011	透明亮效果	Transparent	1.0~1.2	15.0~11.0	
★ CI-G6011	膠水	Glue	0.9~1.1	15.0~11.0	
★ CI-R8011	3D 浮雕效果	3D Relief Effect	1.0~1.2	19.0~11.0	
★ CI-R8211	3D 浮雕效果	3D Relief Effect	1.2~1.4	19.0~11.0	
CI-F0011	清洗液	Cleaner	0.8~1.0	-	
CI-F0022	保護液	Protection Fluid	0.8~1.0	-	

★ 屬訂貨生產之產品，訂貨之交貨期限 1 個月

★ Produced by order, one month for production delivery.

防滑釉 Anti-Slip Glaze

編號 No	燒成條件 Firing Range	使用說明 Descriptions
CG-434 (XG-4163)	1160~1190°C	此產品為適用一次燒地磚使用之止滑釉。 Anti-slip glaze used in floor tiles.
CG-443	1190~1220°C	此產品為一次燒石英磚使用之止滑釉，適合噴墨。 Anti-slip glaze used in homogeneous tiles, suitable for ink jet
CG-449	1190~1220°C	此產品為一次燒石英磚使用之止滑釉，適合噴墨。 Anti-slip glaze used in homogeneous tiles, suitable for ink jet.

測試方法 Test method

A. 儀器 EXCEL English XL VIT

本測試防滑係數方式以美國儀器 EXCEL English XL VIT 為主，於磚面噴少許水，再以儀器來判讀測試數據（可反覆測試，求一平均數）。

依 ASTM 標準：0.5 以上代表安全。

The test method of anti-slip coefficient is mainly done by American instrument EXCEL English XL VIT, to spray a little water on tile surface and discern test data by the instrument (able to test it repeatedly for an average).

According to the ASTM : above 0.5 stands for safe.

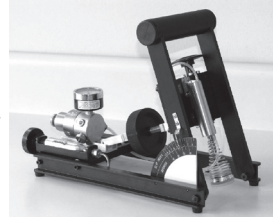

測試值 Value	< 0.39		0.4-0.49	0.5-0.59	0.6-0.79	> 0.8
等級 Grade	非常危險 Very dangerous	危險 Dangerous	相對安全 Relatively safe	安全 Safe	非常安全 Very safe	

B. 儀器 Pendulum Skid Tester(CRT-PENDULUM)

本測試防滑係數方式以英式擺錘抗滑試驗儀為主，於磚面噴少許水，再以儀器來判讀測試數據（可反覆測試，求一平均數）

依 AS4586:2013 標準

BPN= 44 以下都有滑倒風險存在，BPN= 45 以上滑倒風險低。

The anti-skid coefficient method of this test is mainly based on the British pendulum anti-skid tester, spray a little water on the brick surface, and then use the instrument to judge the test data (the test can be repeated and get an average).

According to AS4586:2013 standard:

BPN= 44 and below all have a slip risk, BPN= 45 and above the slip risk is low.

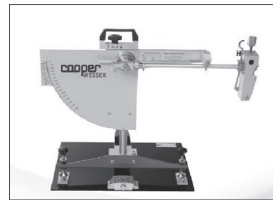

滑塊 96 測試值 SLIDER 96 Value	< 12	12-24	25-34	35~44	45~54	> 54
滑倒風險 Slip risk	極高 Extremely high	非常高 Very high	高 High	中等 Moderate	低 Low	非常低 Very low
P class	P0	P1	P2	P3	P4	P5

* 以上數值僅供參考 For reference only.

施釉地磚耐磨耗性試驗法 (CNS R3299-6)

研磨材料規定如下 (Abrasive specifications) :

- 直徑 1mm 之鋼球 10.00g (1mm diameter steel ball 10.00g)
- 直徑 2mm 之鋼球 45.00g (2mm diameter steel ball 45.00g)
- 直徑 3mm 之鋼球 50.00g (3mm diameter steel ball 50.00g)
- 直徑 5mm 之鋼球 70.00g (5mm diameter steel ball 70.00g)
- #80 之白色氧化鋁 3.00g (white aluminum oxide F80 3.00g)
- 20g 之去離子水或蒸餾水 (20g of deionized water or distilled water)
- 設定轉速為 100、150、600、750、1500、2100、6000、21000

The number of revolutions for every stage of abrasion is 100、150、600、750、1500、2100、6000、21000。

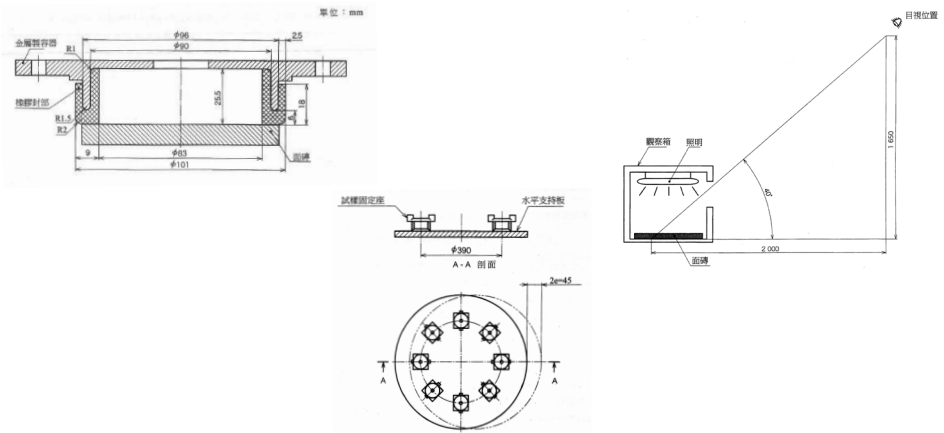

耐磨耗性評定之等級分類

Classification of abrasion resistance of glazed tiles(PEI method)

等級 Class	認定有變化時之磨耗迴轉數 Stage of abrasion visible damage (revolutions)
0	100
1	150
2	600
3	750, 1500
4	2100, 6000, 12000
5	磨耗迴轉數大於 12000 迴轉時，無法認定有變化時 >12000(Must pass the test indicated in ISO 10.545-14 for stain resistance)

*ISO14545 LUX300/CNS 3299-6 LUX500

Composition, Density and Hardness of Material Used in Ceramic Tiles

陶瓷業常用之礦石比重及硬度表 (1/2)

Material 礦石	Molecular Formula 分子式	Density 比重	Mohs 硬度
Albite 鈉長石	$\text{Na}_2\text{OAl}_2\text{O}_3\cdot 6\text{SiO}_2$	2.6	6~7
Arsenic 三氧化砷	As_2O_3	3.6~3.9	3~3.5
Anorthite 鈣長石	$2(\text{CaOAl}_2\text{O}_3)\cdot 4\text{SiO}_2$	2.7	6~7
Apatite 磷灰石	$(\text{CaF})\text{Ca}_4(\text{PO}_4)_3$	2.9~3.2	5
Aragonite 文石	CaCO_3	2.93	3.5~4
Barite 重晶石	BaSO_4	4.3~4.6	2.5~3.5
Beryl 綠寶石	$\text{Be}_3\text{Al}_2(\text{SiO}_3)_6$	2.6~2.8	7.5~8
Boracite 方硼石	$\text{Mg}_3\text{B}_7\text{O}_{13}\text{Cl}$	2.9~3.0	7
Calcite 方解石	CaCO_3	2.95	
Carnallite 光鹵石	$\text{KClMgCl}_2\cdot 6\text{H}_2\text{O}$	1.621	1
Cassiterite 錫石	SnO_2	6.8~7.1	6~7
Celestine 天青石	SrSO_4	3.9	3~3.5
Cerussite 白鉛礦	PbCO_3	6.5	3~3.5
Chalcedony 玉髓	SiO_2	2.6	6.5~7
Chrysoberyl 金綠寶石	BeOAl_2O_3	3.65~3.75	8.5
Cobaltite 輝砷鈷礦	CoAsS	6	5.5
Corundum 剛玉	Al_2O_3	3.9~4.31	9
Cuprite 赤銅礦	Cu_2O	5.85~6.15	3.5~4
Dolomite 白雲石	$\text{CaCO}_3\cdot \text{MgCO}_3$	2.8~2.9	3.5~4
Potash Feldspar 鉀長石	$\text{K}_2\text{OAl}_2\text{O}_3\cdot 6\text{SiO}_2$	2.39~2.62	6
Flint 燧火石	SiO_2	2.6~2.64	7

陶瓷業常用之礦石比重及硬度表 (2/2)

Material 礦石	Molecular Formula 分子式	Density 比重	Mohs 硬度
Fluorspar 螢石	CaF_2	3~3.3	4
Galena 方鉛礦	PbS	7.4~7.6	2.5
Gypsum 石膏	$\text{CaSO}_4 \cdot 2\text{H}_2\text{O}$	2.3	1.5~2
Red-Hematite 赤鐵礦	Fe_2O_3	4.9~5.3	5.5~6.5
Kainite 鉀鹽鎂礬	$\text{KMg}(\text{SO}_4)\text{Cl} \cdot 2.75\text{H}_2\text{O}$	2.1	2.5~3
Kaolin 高嶺土	$\text{Al}_2\text{O}_3 \cdot 2\text{SiO}_2 \cdot 2\text{H}_2\text{O}$	2.5	1
Lepidolite 鋰雲母	$\text{K}(\text{Li},\text{Al})_3(\text{Si},\text{Al})_4\text{O}_{10}(\text{F},\text{OH})_2$	2.8~2.9	2.5~4
Magnesite 菱鎂礦	MgCO_3	3~3.1	3.5~4.5
Magnetite 磁鐵礦	Fe_3O_4	4.9~5.2	5.5~6.5
Sepiolite 海泡石	$\text{Mg}_4\text{Si}_6\text{O}_{15}(\text{OH})_2 \cdot 6\text{H}_2\text{O}$	2	2~2.5
Biotite 黑雲母	$(\text{HK})_2(\text{MgFe})_2\text{Al}_2(\text{SiO}_4)_3$	2.7~3.1	2~2.5
Red Lead 紅鉛 (丹)	Pb_3O_4	8.3~9.2	2~2.5
Natrolite 鈉沸石	$\text{Na}_2\text{Al}_2\text{Si}_3\text{O}_{10} \cdot 2\text{H}_2\text{O}$	2.24~2.25	5~5.5
Nepheline 霞石	$\text{Na}_6\text{K}_2\text{Al}_8\text{Si}_9\text{O}_{34}$	2.55~2.65	5.5~6
Olivine 橄欖石	Mg_2SiO_4	3~4.3	6~7
Orthoclase 正長石	$\text{K}_2\text{OAl}_2\text{O}_3 \cdot 6\text{SiO}_2$	2.39~2.46	6
Petalite 葉長石	$\text{Li}_2\text{O} \cdot \text{Al}_2\text{O}_3 \cdot 8\text{SiO}_2$	2.39~2.46	6~6.5
Pollucite 鉀石榴子石	$(\text{CsNa})_2\text{Al}_2\text{O}_3 \cdot 5\text{SiO}_2 \cdot \text{H}_2\text{O}$	2.868	
Pyrolusite 軟錳礦	MnO_2	4.8~4.9	2~2.5
Rutile 金紅石	TiO_2	4.2~4.3	6~6.5

Specification of Ceramic Materials

各種陶瓷主要原料性質表

品名	化學式	分子量	熔融後 氧化物	氧化物 分子量	換算因素	膨脹因素 ($\times 10^{-7} \text{°C}$)	熔點 (°C)
氫氧化鋁	$\text{Al}_2(\text{OH})_6$	156	Al_2O_3	102	0.654	3.23	$-\text{H}_2\text{O}$ 300 分解
氧化鋁	Al_2O_3	102	Al_2O_3	102	1	5	2050
碳酸鋇	BaCO_3	197	BaO	153	0.777	2.33	900°C 分解 1360°C 融解
骨灰	$\text{Ca}_3(\text{PO}_4)_2$	310	CaO	56	0.542	2.3	1550
			P_2O_5	142	0.458		
無水硼砂	$\text{Na}_2\text{O} \cdot 2\text{B}_2\text{O}_3$	202	Na_2O	62	0.307	3.15	732
			B_2O_3	70	0.693		
十水硼砂	$\text{Na}_2\text{O} \cdot 2\text{B}_2\text{O}_3 \cdot 10\text{H}_2\text{O}$	382	Na_2O	62	0.162	1.66	赤熱
			B_2O_3	70	0.366		
硼酸	$\text{B}_2\text{O}_3 \cdot 3\text{H}_2\text{O}$	124	B_2O_3	70	0.565	0.056	184~186
氧化鈷	CoO	75	CoO	75	1	4.1	2860
氟矽化鈉	Na_2SiF_6	188	Na_2O	62	0.33	7.4	分解
			SiO_2	60	0.32		
氟化鈣	CaF_2	78	CaO	56	0.718	2.5	1300
氧化鐵	Fe_2O_3	160	Fe_2O_3	160	1.05	4	1560 分解
高嶺土	$\text{Al}_2\text{O}_3 \cdot 2\text{SiO}_2 \cdot 2\text{H}_2\text{O}$	258	Al_2O_3	102	0.395	2.36	1755~1790
			SiO_2	60	0.465		
紅丹	Pb_3O_4	685	PbO	223	0.975	4.1	500 分解
氧化鉛	PbO	223	PbO	223	1	4.2	888
碳酸鋰	Li_2CO_3	74	Li_2O	30	0.405	4.05	618~710
碳酸鎂	MgCO_3	84	MgO	40	0.476	0.048	350 分解
碳酸錳	MnCO_3	115	MnO	71	0.61	1.66	分解
二氧化錳	MnO_2	87	MnO	71	0.817	2.2	0
氧化鎳	NiO	75	NiO	75	1	4	400
碳酸鉀	K_2CO_3	138	K_2O	94	0.68	5.78	896
硝酸鉀	KNO_3	101	K_2O	94	0.465	3.96	337
葉臘石	$\text{Al}_2\text{O}_3 \cdot 4\text{SiO}_2 \cdot \text{H}_2\text{O}$	360	Al_2O_3	102	0.283	1.63	$-\text{H}_2\text{O}$ 600 分解
			SiO_2	60	0.666		
石英	SiO_2	60	SiO_2	60	1	0.8	1600~1750
碳酸鈉	Na_2CO_3	106	Na_2O	62	0.585	5.85	849
硝酸鈉	NaNO_3	85	Na_2O	62	0.365	3.65	310
			SiO_2	60	0.784		
			Li_2O	30	0.049		
葉長石	$\text{Li}_2\text{O} \cdot \text{Al}_2\text{O}_3 \cdot 8\text{SiO}_2$	612	Al_2O_3	102	0.168	2.45	
			MgO	40	0.319		
			SiO_2	60	0.634		
滑石	$3\text{MgO} \cdot 4\text{SiO}_2 \cdot \text{H}_2\text{O}$	378	MgO	40	0.319	0.539	$-\text{H}_2\text{O}$ 500 分解
氧化錫	SnO_2	151	SnO_2	151	1	2	1127
氧化鈦	TiO_2	80	TiO_2	80	1	4.1	1560
石灰石	CaCO_3	100	CaO	56	0.56	2.8	825 分解
氧化鋅	ZnO	81	ZnO	81	1	1.80	>1800
氧化鋯	ZrO_2	123	ZrO_2	123	1	2.1	2700
			ZrO_2	123	0.672	1.62	2550
矽酸鋯	ZrSiO_4	183	SiO_2	60	0.328		

Standard Mesh Sizes of Wires Sieve Trays for Analysis Sieves (extracts)

各國標準篩對照表

JIS		Din4188(1997) AFNORNF*11-501 (France)(1970)	TYLER Standard Screen Scale (1910) Mesh (mesh/in)	ASTME 11-70 (USA)(1970)No.	BS410 Appendix C(GB)(1976) Mesh(mesh/in)	mm
μ	Mm					
		8	2/12	5/10		8
		7.1				
			3	0.265		6.7
		6.3		1/4		
5660	5.660	5.6	3 1/2	3 1/2	3	5.6
		5				
4760	4.760		4	4	3 1/2	4.75
		4.5				
4000	4.000	4	5	5	4	4
		3.55				
3360	3.360		6	6	5	3.35
		3.15				
2830	2.830	2.8	7	7	6	2.8
		2.5				
2380	2.380		8	8	7	2.36
		2.24				
2000	2.000	2	9	10	8	2
		1.8				
1680	1.680		10	12	10	1.7
		1.6				
1410	1.410	1.4	12	14	12	1.4
		1.25				
1190	1.190		14	16	14	1.18
		1.12				
1000	1.000	1	16	18	16	1
		0.9				
840	0.840		20	20	18	0.85
		0.8				
710	0.710	0.71	24	25	22	0.71
		0.63				
590	0.590		28	30	25	0.6
		0.56				
500	0.500	0.5	32	35	30	0.5
		0.45				
420	0.420		35	40	36	0.425
		0.4				
350	0.350	0.355	42	45	44	0.355
		0.315				
297	0.297		48	50	52	0.3
		0.28				
250	0.250	0.25	60	60	60	0.25
		0.224				
210	0.210		65	70	72	0.212
		0.2				
177	0.177	0.18	80	80	85	0.18
		0.16				
149	0.149		100	100	100	0.15
		0.14				
125	0.125	0.125	115	120	120	0.125
		0.112				
105	0.105		150	140	150	0.106
		0.1				
88	0.088	0.09	170	170	170	0.09
		0.08				
74	0.074		200	200	200	0.075
		0.071				
62	0.062	0.063	250	230	240	0.063
		0.056				
53	0.053		270	270	300	0.053
		0.05				
44	0.044	0.045	325	325	350	0.045
		0.04				
37	0.037		400	400	400	0.038
		0.036				
33	0.033		425	425	425	0.033
		0.032				
25	0.025		500	500	500	0.025
		0.022				
20	0.020	0.02	625	625	625	0.02
15	0.015	0.015	800	800	800	0.015
10	0.010	0.01	1250	1250	1250	0.01
5	0.005	0.005	2500	2500	2500	0.005
2	0.002		6250	6250	6250	0.002
1	0.001		12500	12500		0.001